



Code Compliance Research Report CCRR-0193

Issue Date: 10-06-2016
Renewal Date: 10-15-2017

Valued Quality. Delivered.

DIVISION: 08 00 00 – OPENINGS
Section: 08 62 00 – Unit Skylights

Solatube International, Inc.
2210 Oak Ridge Way
Vista, CA 92081
(760)-597-4400
www.solatube.com

REPORT SUBJECT:
Solatube SkyVault, Model M74 DS

1.0 SCOPE OF EVALUATION

This research report addresses compliance with the following Codes:

- 2012 International Building Code (IBC)
- 2012 International Residential Code (IRC)

Solatube SkyVault Model M74 DS has been evaluated for the following properties:

- Structural Performance
- Durability
- Burning

2.0 USES

2.1. Solatube SkyVault Model M74 DS recognized in this report are plastic glazed unit skylights complying with IBC Sections 2405 and 2610 and IRC Section R308.6.

3.0 DESCRIPTION

3.1. Solatube SkyVault Series Model M74 DS consists of four primary assemblies; single or dual glazed skylight assembly, reflective tube assembly, diffuser assembly, and cylindrical light collector. See Figures 3 and 4.

3.1.1. The curb mounted skylight assemblies are comprised of a dome, thermal disc (only for dual glazed skylights), a dome edge protection band, dome clamps, a tube ring, foam plastic insulation with a closed cell foam infiltration seal, and a curb cap with closed cell foam weather strips.

3.1.1.1. The dome is manufactured from Makrolon-SL sheet, recognized in ICC-ES Evaluation Report, ESR-2728.

3.1.1.2. A thermal disc is utilized in dual glazed skylights, and consists of a 0.040 inch thick PET material, complying with IBC Section 2606.4 with a plastic classification of CC1 or CC2.

3.1.1.3. A dome edge protection band is manufactured from 0.022 inch thick by 7/8 inch wide steel sheet.

3.1.1.4. A dome retainer band, manufactured from 0.031 inch thick steel sheet, with four dome retainer clamps, manufactured from 0.064 inch thick steel sheet, attach the dome and the dome edge protection band to the curb cap.

3.1.1.5. Closed cell foam is utilized between the mating surfaces of the dome and curb cap. Closed cell foam is also utilized between the curb cap and wood curb.

3.1.1.6. A tube ring is a 28-1/2 inch diameter, (minimum) 0.018" thick aluminum sheet metal tube formed with rivets through the overlap seam and with a reflective coating on the interior face. It is utilized to connect the top of an extension tube to the curb cap assembly via interlocking joints. A metal belt and torsion spring clamp secure the interlocking joint assembly.

3.1.1.7. The foam plastic insulation is of 1 inch thickness, manufactured in accordance with ESR-1864 or ESR-1659. The foam plastic insulation complies with the code requirements for use in attics and crawl spaces without an ignition barrier and does not require a thermal barrier.

3.1.1.8. The curb cap is manufactured from 0.028 inch steel sheet and is mounted to a roof mounted curb provided by others to form the base of the skylight assembly.

3.1.2. Reflective tube assemblies are comprised of (minimum) 0.018" thick, 28-1/2 inch diameter aluminum tubes with a reflective coating on the interior face of the tube. Tubes have six equally spaced tabs on the ends

to enable interlocking with additional tubes, tube rings or diffuser collars. A metal belt and torsion spring clamp are utilized to secure the interlocking joints to secure the assembly.

3.1.3. Daylight Dimmer assembly is switch operated and electrically driven, available for installation between transition tubes on the M74 DS models. The Dimmer Assembly is used to restrict natural light from entering the room. See Section 7.4.

3.1.4. The thermal insulation panel assembly includes two thermal disks that are of 0.06" plastic sheets complying with IBC Section 803.1 and IBC Section 2606.4, and are available for installation within the reflective tube assembly. The thermal insulation panel is used to add insulation to the tube assembly for increased thermal performance.

3.1.5. Diffuser assemblies are comprised of a prismatic panel diffuser, diffuser collar, and closed cell sponge rubber dress ring.

3.1.6. The prismatic panel diffuser is a single glazed acrylic diffuser with a plastic classification of CC2. The prismatic panel diffuser has twelve evenly spaced holes around its perimeter that fit the tabs of the diffuser collar.

3.1.6.1. A diffuser collar is utilized to connect the bottom of an extension tube to the prismatic panel diffuser. Diffuser collars have six tabs on one end and twelve on the other to enable interlocking with the extension tubes and prismatic panel diffuser, respectively.

3.1.6.2. A closed cell sponge rubber dress ring is snap-fitted around the perimeter of the prismatic panel diffuser

3.1.6.3. Amplifier diffuser assemblies use a, tube manufactured of sheet metal that transitions the diffuser from a 28-1/2 inch diameter to 36 inch diameter.

3.1.7. M74 DS Cylindrical Light Collector Assembly is comprised of wire ropes, a cylinder assembly, a dome, clamps, retainers, and rivets. See Figure 4.

3.1.7.1. Wire ropes consist of stranded, 3/32 inch diameter stainless steel ropes, utilized for bracing the height of the cylindrical light collector.

3.1.7.2. The cylinder assembly consists of two primary components: a metal reflector sheet in one half

of the cylinder circumference and plastic glazing in the other half. The metal and the plastic sheets are attached with a sheet steel cleat and rivets to assemble a cylindrical shape.

3.1.7.3. The dome is manufactured from Makrolon-SL sheet, recognized in ICC-ES Evaluation Report, ESR-2728, effective September 1, 2013

3.1.7.4. Two types of clamps: Four stainless steel clamps attach the ropes to the top of the cylindrical light collector at the dome, while four sheet steel clamps attach the wire ropes to the curb cap at the corners. A retainer band is used in conjunction with the stainless steel clamps to secure the dome to the top of the cylindrical light collector.

4.0 PERFORMANCE CHARACTERISTICS

4.1. The M74 DS Model identified in this report has been tested for deflection and structural response under uniform loading in both the positive (inward) and negative (outward) directions in accordance with ICC-ES AC16. The maximum allowable positive and negative design loads are indicated in Table 1.

4.2. The M74 DS Cylindrical Light Collector Assembly identified in this report has been tested for lateral static loading to a safety factor of 2.5 in accordance with IBC Section 1710.3.1. The maximum allowable lateral design loads are indicated in Table 2.

4.3. The prismatic panel diffusers have a self-ignition temperature of 650°F (343°C) or greater when tested in accordance with ASTM D 1929, a smoke development index not exceeding 75 when tested in accordance with ASTM D 2843, a plastic classification of CC2 when tested in accordance with ASTM D 635, and comply with the installation requirements of IBC Section 2606.7.2.

4.4. The M74 DS Model identified in this report has met the air infiltration and water penetration acceptance criteria identified in ICC-ES AC16 when tested in accordance with Sections 9.3.2 and 9.3.3 of AAMA/WDMA/CSA 101/I.S.2/A440-11.

5.0 INSTALLATION

Solatube SkyVault Series Model M74 DS must be installed in accordance with the manufacturer's published installation instructions, the applicable Code and this Research Report. The manufacturer's published installation instructions and this Research

Report must be strictly adhered to, and a copy of the instructions must be available on the jobsite during installation.

5.1. Skylights shall be mounted on a wood, steel, aluminum, or concrete curb that raises the plastic glazing at least 4 inches above the plane of the roof.

5.2. The outside curb dimensions are indicated in Tables 3 & 4. The design, attachment, flashing and placement of the curb to the roof deck is outside the scope of this report.

5.3. Skylights shall be attached to the curb utilizing fasteners described in this report. See Table 3 for fastener details. A maximum 1/2" shim space is permitted between the curb and the curb cap.

5.4. The M74 DS cylindrical light collector is attached to the top of the M74 DS curb cap flashing with wire ropes, clamps, and screws. See Figure 4.

6.0 SUPPORTING EVIDENCE

6.1. Manufacturer's drawings and installation instructions.

6.2. Reports of testing and engineering analysis in accordance with ICC-ES AC16, Acceptance Criteria for Plastic Glazed Skylights, approved April 2011.

6.3. Reports of testing in accordance with AAMA/WDMA/CSA101/I.S.2/A440-11 "Standard/Specification for Windows, Doors, and Unit Skylights", American Architectural Manufacturers Association, Window and Door Manufacturers Association, and Canadian Standards Association.

6.4. ICC-ES Evaluation Report ESR-1407 for thermal insulation panel plastic sheet material compliance with IBC Section 803.1 and IBC Section 2606.4.

6.5. Quality control manual in accordance with ICC-ES AC10, Acceptance Criteria for Quality Documentation, dated June 2014.

7.0 CONDITION OF USE

The Solatube SkyVault Series Model M74 DS described in this Research Report complies with, or is a suitable alternative to, what is specified in those Codes listed in Sections 1.0 and 2.0 of this report, subject to the following conditions:

7.1. Installation must comply with this Research Report, the manufacturer's published installation instructions and the applicable Code. In the event of a conflict between the manufacturer's instructions and this report, this report governs.

7.2. Unless the building is equipped throughout with an automatic sprinkler system in accordance with IBC Section 903.3.1.1, the light diffusing system shall not be installed in the following occupancies and locations:

- Group A with an occupant load of 1,000 or more.
- Theaters with a stage and proscenium opening and an occupant load of 700 or more.
- Group I-2
- Group I-3
- Interior exit stairways and ramps and exit passageways.

7.3. The light-transmitting plastic material of the prismatic panel diffuser complies with Section 2606.7.2 of the IBC. The diffuser may be used in all occupancies where it does not exceed 10 percent of the specific ceiling area in which it is attached.

7.4. Daylight dimmer assembly has only been evaluated for effects on performance when TDDs were tested in accordance with ICC-ES AC16. Evaluation of these assemblies for compliance to electrical codes is not part of this report.

7.5. The wind uplift rating recognized in this report is based on attachment to curbs and corresponding fasteners as described in Tables 3 & 4.

7.6. The status of this report is contingent on the validity of the ICC-ES reports identified herein. The revocation or expiration of any included ICC-ES reports will invalidate this report.

7.7. Where required by the building official, engineering calculations and details shall be provided. The calculations shall verify that the anchorage complies with the building code for the type of framing and condition of the supporting construction.

7.8. The Solatube SkyVault Series is manufactured in accordance with the manufacturer's approved quality control system with inspections by Keystone Certifications, Inc. (IAS AA-714).

8.0 IDENTIFICATION

The Solatube SkyVault Series produced in accordance with this report shall be identified with permanent labeling that includes the following information:

- 8.1.** The manufacturer's name and/or logo, address, model number and allowable loads.
- 8.2.** The plastic dome glazing thickness and classification (CC1).
- 8.3.** Safety labeling indicating "Risk of Fall" that complies with Class 1, ANSI Standard Z35.1 specifications for accident prevention signs.
- 8.4.** The name or logo of the independent inspection agency, Keystone Certifications, Inc. (IAS AA-714).
- 8.5.** The Intertek Code Compliance Research Report mark and report number (CCRR-0193).



9.0 CODE COMPLIANCE RESEARCH REPORT

- 9.1.** Approval of building products and/or materials can only be granted by a building official having legal authority in the specific jurisdiction where approval is sought.
- 9.2.** Code Compliance Research Reports shall not be used in any manner that implies an endorsement of the product by Intertek.
- 9.3.** Reference to the Intertek website address: whdirectory.intertek.com is recommended to ascertain the current version and status of this report.

This Code Compliance Research Report ("Report") is for the exclusive use of Intertek's Client and is provided pursuant to the agreement between Intertek and its Client. Intertek's responsibility and liability are limited to the terms and conditions of the agreement. Intertek assumes no liability to any party, other than to the Client in accordance with the agreement, for any loss, expense or damage occasioned by the use of this Report. Only the Client is authorized to permit copying or distribution of this Report and then only in its entirety, and the Client shall not use the Report in a misleading manner. Client further agrees and understands that reliance upon the Report is limited to the representations made therein. The Report is not an endorsement or recommendation for use of the subject and/or product described herein. This Report is not the Intertek Listing Report covering the subject product and utilized for Intertek Certification and this Report does not represent authorization for the use of any Intertek certification marks. Any use of the Intertek name or one of its marks for the sale or advertisement of the tested material, product or service must first be approved in writing by Intertek.

Table 1 – M74 DS Curb Mounted Skylight Maximum Allowable Design Loads

Skylight Description			Glazing Description			Wind Loads (psf) ⁽¹⁾
Model Series	Model No.	Dome Rise (inch)	Glazing Material	Glazing Thickness (inch)	Diameter (inch)	
<i>SkyVault</i> (See Figures 1 & 3)	M74 DS	5-7/8 ⁽²⁾	Makrolon-SL (ESR-2728)	0.118	28-1/2	+80 -80

⁽¹⁾ Positive (+) loads are directed inward; negative (-) are directed outward. All positive design pressures were tested to a safety factor of 3. All negative design pressures were tested to a safety factor of 2.

⁽²⁾ Dome rise is the height measured from the top surface of the curb cap flashing to the top of the plastic dome.

Table 2 – Cylindrical Light Collector Maximum Allowable Design Loads

Description	Cylinder Assembly		Lateral Design Loads (psf) ⁽¹⁾
	Dome Cylinder Plastic (half circumference)	Cylinder Reflector (half circumference)	
<i>SkyVault</i> M74 DS with Cylindrical Light Collector (See Figures 2 & 4)	Makrolon-SL (ESR-2728) 0.093 inch thick	0.028 inch thick sheet steel	69.7

⁽¹⁾ Lateral loads were tested to a safety factor of 2.5 in accordance with IBC Section 1710.3.1.

Table 3 – M74 DS Curb and Fastener Schedule

Outside Curb Dimensions	Curb			Fastener (Curb Cap to Curb)		
	Material	Min. Thickness ⁽¹⁾	Properties ⁽¹⁾	Description	Qty.	Spacing
34-3/8" x 34-3/8"	2x8 Spruce-Pine-Fir	2" Nominal Wood Blocking	Specific Gravity, G=0.42	#8 x 2" Phillips truss head self-pierce sheet metal screw	16	Spaced 2-1/2" and 10" on center from each corner for a total of four fasteners per side.
				#10 x 2" wood screw		
	33 ksi Steel (ASTM A653)	18 Gauge (0.0451")	F _y = 33 ksi F _u = 45 ksi	#10-16 SAE Grade 5 TEKS screw with minimum 3 threads past the curb substrate	16	Spaced 2-1/2" and 10" on center from each corner for a total of four fasteners per side.
	3105-H14 Aluminum	0.0508"	F _{tu} = 25 ksi F _y = 22 ksi	#10-24 300 Series stainless steel sheet metal screw with minimum 3 threads past the curb substrate	16	Spaced 2-1/2" and 10" on center from each corner for a total of four fasteners per side.
Normal Weight Concrete	4"	f _c = 2,500 psi	3/16" ITW Tapcon Anchor (ESR-2202) with min. embedment of 1-1/2"	16	Spaced 2-1/2" and 10" on center from each corner for a total of four fasteners per side.	

⁽¹⁾ Installation on a curb substrate with a lesser thickness or lesser mechanical properties may result in a lower wind load rating.

Table 4 – M74 DS Collector Assembly, Curb Installation Fastener Schedule

Outside Curb Dimensions	Curb			Fastener (Collector with Curb Cap to Curb)		
	Material	Min. Thickness ⁽¹⁾	Properties ⁽¹⁾	Description	Qty.	Spacing
34-3/8" x 34-3/8"	2x8 Spruce-Pine-Fir	2" Nominal Wood Blocking	Specific Gravity, G=0.42	#8 x 2" Phillips truss head self-pierce sheet metal screw #10 x 2" truss head screw	24	Spaced 2-1/2", 10" and 16-1/2" on center from each corner for a total of six fasteners per side.
	33 ksi Steel (ASTM A653)	18 Gauge (0.0451")	F _y = 33 ksi F _u = 45 ksi	#10-16 SAE Grade 5 TEKS screw with minimum 3 threads past the curb substrate	24	Spaced 2-1/2", 10" and 16-1/2" on center from each corner for a total of six fasteners per side.
	3105-H14 Aluminum	0.0508"	F _{tu} = 25 ksi F _{ty} = 22 ksi	#10-24 300 Series stainless steel sheet metal screw with minimum 3 threads past the curb substrate	24	Spaced 2-1/2", 10" and 16-1/2" on center from each corner for a total of six fasteners per side.
	Normal Weight Concrete	4"	f' _c = 2,500 psi	3/16" ITW Tapcon Anchor (ESR-2202) with min. embedment of 1-1/2"	24	Spaced 2-1/2", 10" and 16-1/2" on center from each corner for a total of six fasteners per side.

⁽¹⁾ Installation on a curb substrate with a lesser thickness or lesser mechanical properties may result in a lower wind load rating.

Table 5 – M74 DS Collector Assembly and Collector to Curb Cap Connection Details

Connection	Fastener (Collector to Curb Cap and Curb Cap to Curb)		
	Description	Qty.	Locations
M74 DS Wire Rope to M74 DS Dome Retainer Band Assembly	#10-24 x 1.25" hex washer head, stainless steel screw with a #10-24 aluminum rivet nut	4	Unions are attached at four locations equidistant along the circumference of the Dome Retainer Band.
	M74 DS Union	4	
M74 DS Dome Ring to M74 DS Dome Cylinder Back to M74 DS Cone Base	M74 DS Dome Ring	1	Eight rivets are placed along the upper edge of the Dome Cylinder Back to connect to the Dome Ring.
	M74 DS Dome Cylinder Back	1	
	M74 DS Cone Base	1	Eight rivets are placed along the lower edge of the Dome Cylinder Back to connect to the Cone Base.
	1/8" diameter x 1/4" Rivet	16	
M74 DS Dome Ring to M74 DS Stanchion to M74 DS Cross Beam to M74 DS Cone Base	M74 DS Dome Ring	1	Two rivets are placed at each end of each Stanchion to connect it to the Cone Base on the bottom and the Dome Ring and Cross Beam at the top.
	M74 DS Stanchion	2	
	M74 DS Cross Beam	2	Two rivets are placed at each end of each Cross Beam to connect it to the Dome Ring and Cylinder Back on one end the Dome Ring at the other end.
	M74 DS Cone Base	1	
	1/8" diameter x 1/4" Rivet	16	
M74 DS Cleat to M74 DS Cylinder Back	M74 DS Cleat	2	Nine rivets are placed along the edge of each Cleat to connect it to the Cylinder Back.
	M74 DS Cylinder Back	1	
	1/8" diameter x 1/4" Rivet	18	
M74 DS Reflector to M74 DS Cylinder Back	M74 DS Reflector	1	Two Rivets are placed along each vertical side of the reflector to connect it to the Cylinder Back.
	M74 DS Cylinder Back	1	
	1/8" diameter x 1/4" Rivet	4	
M74 DS Cylinder Assembly to M74 DS Curb Cap Flashing Assembly	M74 DS Cone Clamp	4	Clamps are located at four locations at the mid-point of each side of the M74 DS Curb Cap Flashing assembly with four Rivets per clamp.
	M74 DS Cone Base	1	
	M74 DS Curb Cap Flashing	1	
	1/8" diameter x 1/4" Rivet	16	

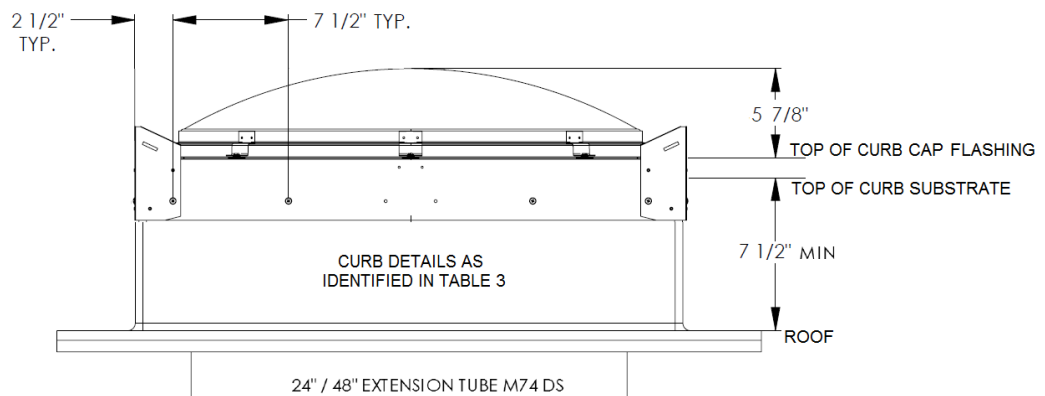

Figure 1 – M74 Curb Dimensions

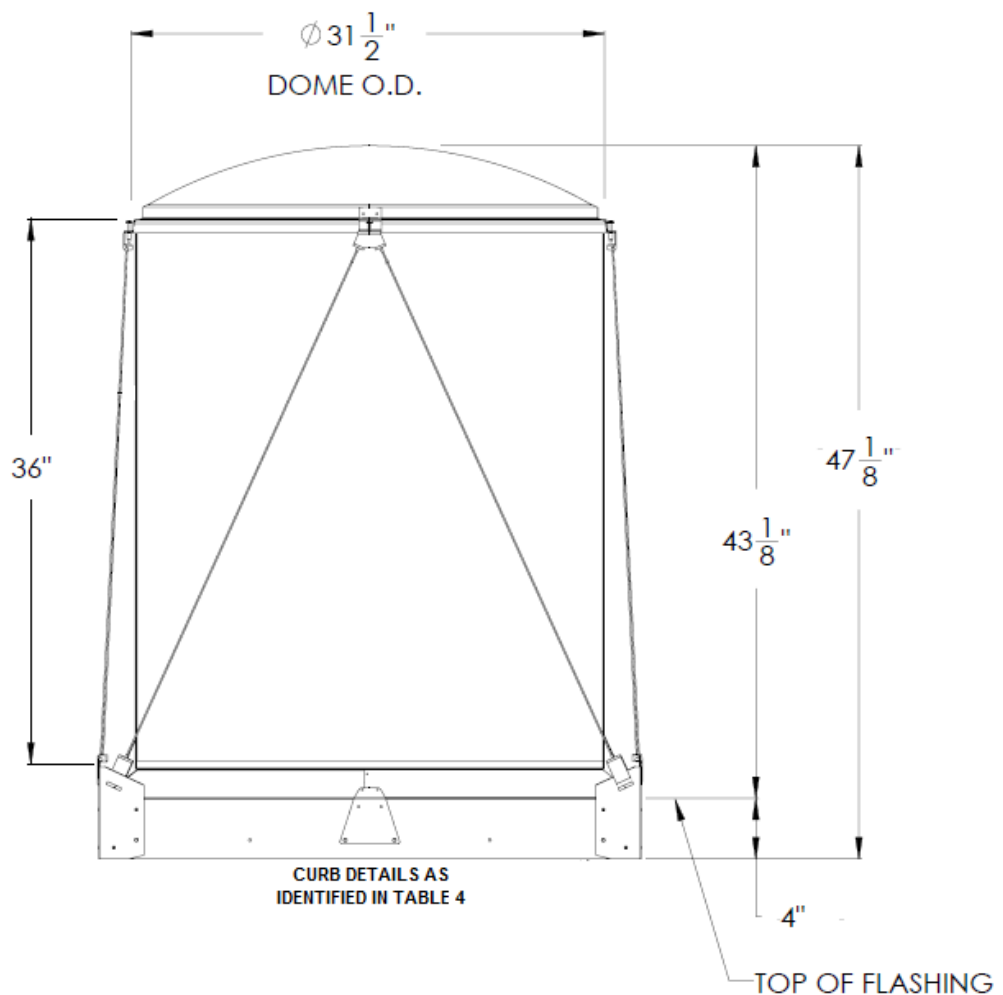

Figure 2 – M74 Collector Assembly Dimensions

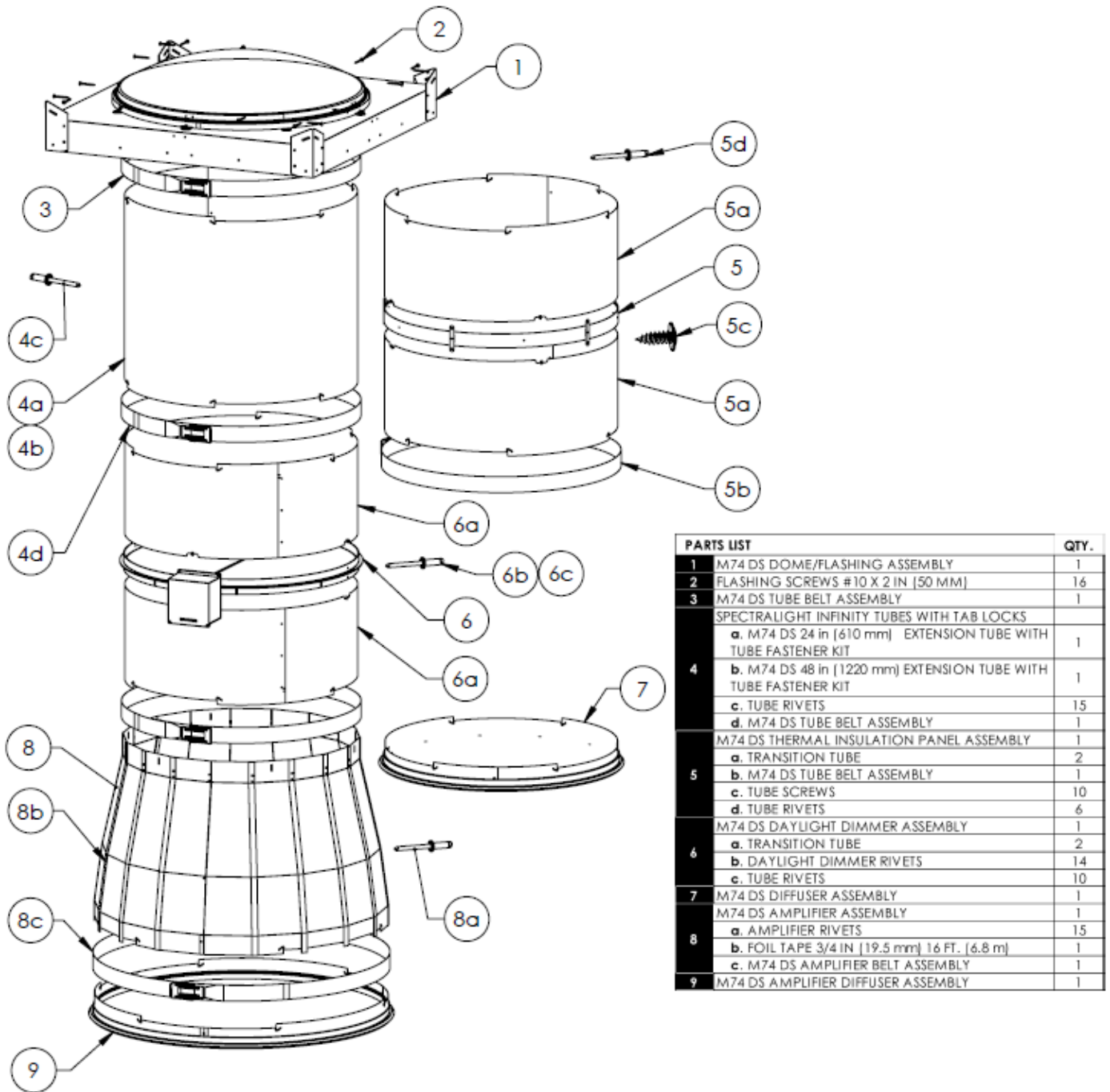
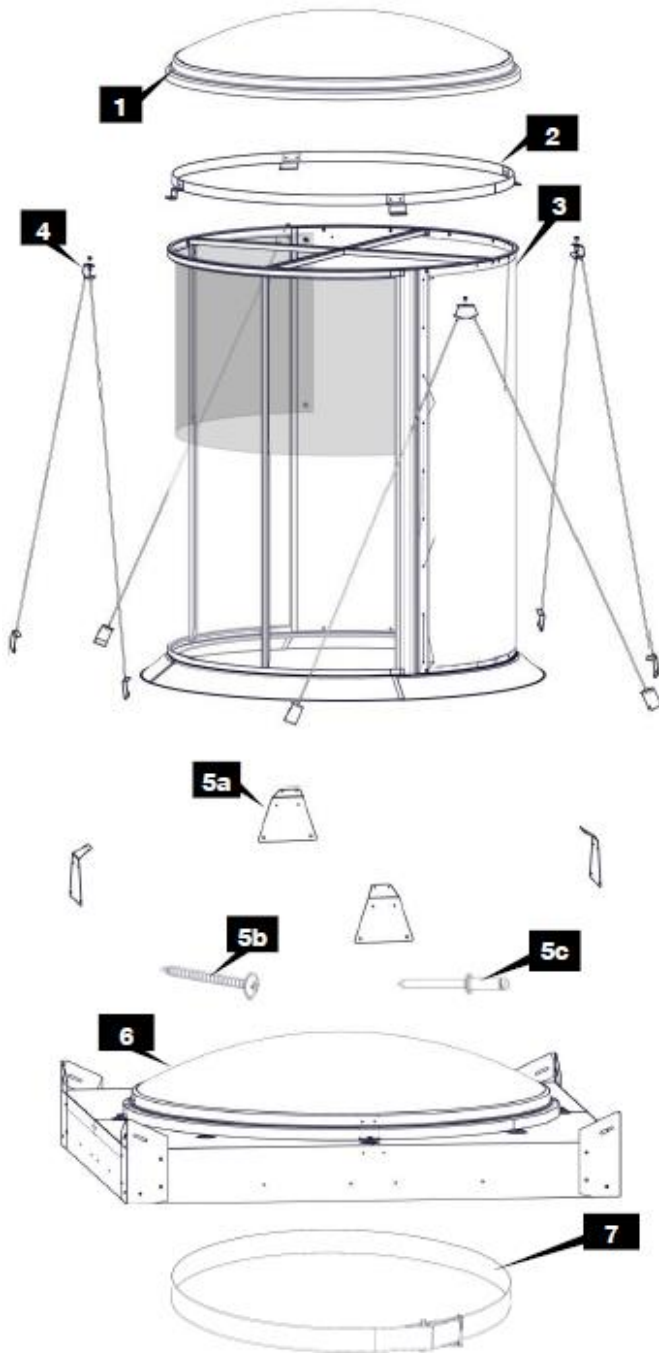

Figure 3 – M74 DS Assembly



Parts List	Quantity
1 M74 DS Dome	(1)
2 Dome Retainer Band Assembly	(1)
3 M74 DS Cylinder Assembly with Raybender HD	(1)
4 Wire Rope Bridge Assembly	(4)
5 Cone Fastener Kit	
a. Cone Clamp	(4)
b. Flashing Screws - #10 X 2 in (50mm)	(24)
c. Cone Clamp Rivet	(17)
6 Pre-Assembled Roof Assembly Options *	(1)
a. M74 DS Single Dome Roof Assembly with Insulated Curb Cap Flashing *†	
b. M74 DS Dual Dome Roof Assembly with Insulated Curb Cap Flashing *†	
c. M74 DS Single Dome Roof Assembly with Insulated Curb Cap Flashing and Security Guard *†	
d. M74 DS Dual Dome Roof Assembly with Insulated Curb Cap Flashing and Security Guard *†	
7 Tube Belt with Belt Latch	(1)

*† Components shown not included in all kits, see label on box.

Figure 4 – M74 DS with Cylindrical Light Collector Assembly
(Add-on to M74 DS Curb Mounted Unit)